

UNIDAD INTERIOR MANEJADORA

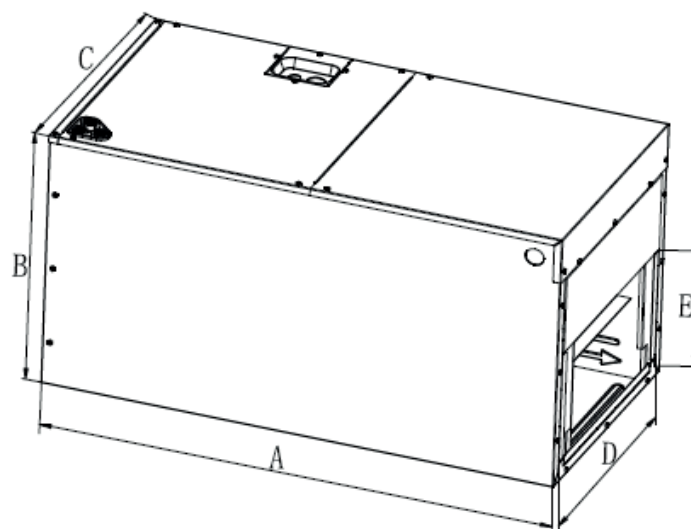

DIMENSIONES:

MODEL	DIMENSIONS (mm)				
	A(HEIGHT)	B(DEPTH)	C(WIDTH)	D	E
36	774	520	460	41 4	245
60	970(11 60)	550	500	454	266

ESPECIFICACIONES TÉCNICAS:



Market model			CAHi-36CNR2	CAHi-60CNR2
Power supply		V/Ph/Hz	208V~230V/1Ph/60Hz	208V~230V/1Ph/60Hz
Cooling	Capacity	Btu/h	36000	60000
External static pressure		pa	37	50
Max. input consumption (indoor unit)		W	290	517
MCA		A	1,50	3,00
Indoor coil	Number of row		2	3
	Fin spacing	mm	1,5	1,5
	Fin material		Hydrophilic Aluminium Fin	Hydrophilic Aluminium Fin
	Tube outside diameter	mm	Φ7	Φ7
	Tube material		Inner Screw	Inner Screw
	Coil length x height x widt	mm	336X26.74X413 (X2)	378X40X443 (X2)
	Number of circuit		4	6
Indoor fan motor	Input	W	240	404
	Output	W	130	250
	Speed (Hi/Lo)	rpm	910/780	800/730
Indoor air flow		m ³ /h	1700	2500
Indoor noise level		dB(A)	51-56	51~57
Indoor dimension	Unit (WxHxD)	mm	460×774×520	500×970×550
	Packing (WxHxD)	mm	834×520×565	1030×560×595
	Net	kg	37	45
	Gross	kg	39	48
Throttle type			Piston	Piston
Power wiring		mm ²	3×1.0	3×1.0
Ambient temperature range		°C	18~43	18~43